

Wall-hung boilers (fan-assisted system)

12KTO/17 PANTHER

00 - General view

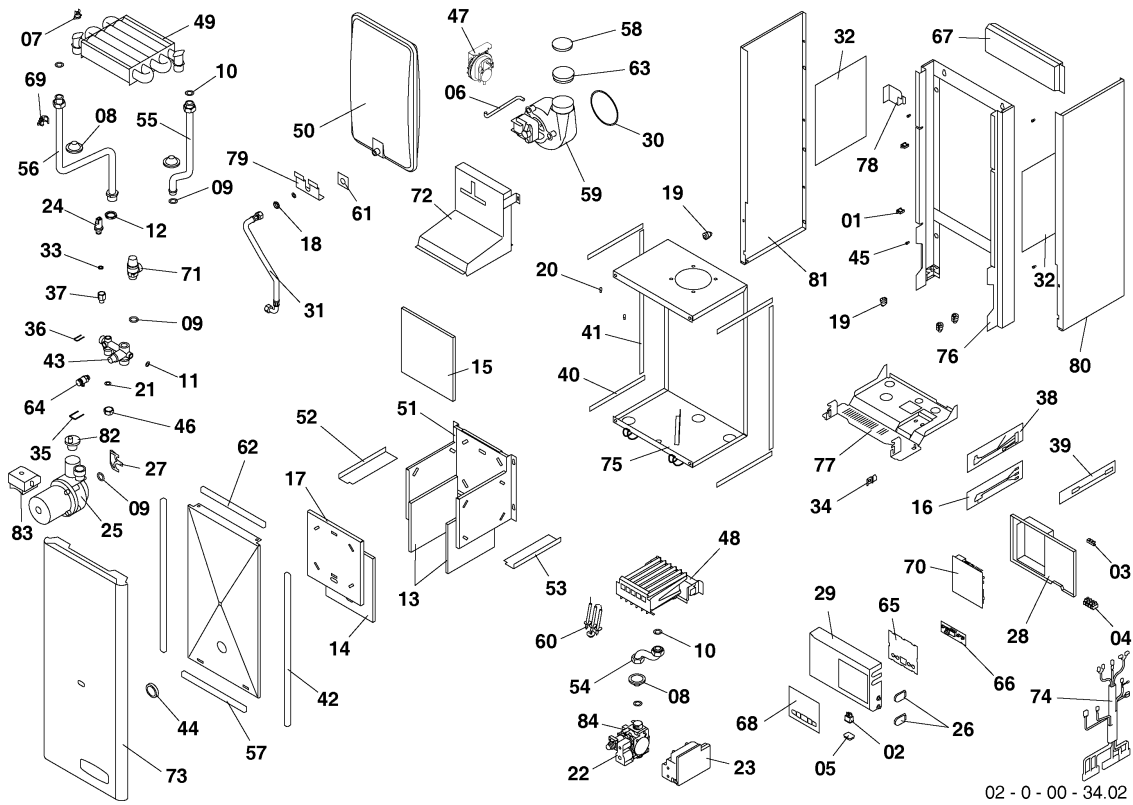

02-0-00-34.02

Wall-hung boilers (fan-assisted system)

12KTO/17 PANTHER

00 - General view

Pos.	Article	Description	Note
01	0020035605	Cable clip F1202 KWS-1N	
02	0020033233	Mains On/Off switch	
03	0020033239	Counterpart 6 poles - 6,3mm	
04	0020033240	Terminal board	
05	0020033241	Bubble of 1 pole switches	
06	0020033263	Silicon hose to manostat	
07	0020027575	Thermostat bim.non-revers.	
08	0020033462	Grommet I 326 14mm	
09	0020033467	O-Ring, 18x3,5, (x10)	
10	0020027665	Sealing ring 24x15x2, (x10)	
11	0020033473	Gasket, 15x8x2, (x10)	
12	0020033624	Nut 3/4 low	
13	0020033524	Insulation SK 184x168	
14	0020033578	Insulation 185x218	
15	0020033580	Insulation 204x218	
16	0020033588	Wire Q009 KJ	
17	0020033780	Comb. chamber front cover 12	
18	0020033836	Nut 3/8 low	
19	0020033838	Plastic cable grommet	
20	0020033921	Limiting pin 70004250	
21	0020033932	Sealing ring, AFM 34 18x10x2, (x10)	
22	05641100	Gas valve G20/G30	
23	0020023214	El. ignition	
24	S5720500	Pressure sensor	
25	0020023217	Pump	available until sold out, then replaced by HE pump
25	0010034148	Pump, high-efficiency	In case of upgrading SD to HE pump please order also adapter 0010030684!
25	0010030684	Plug	
26	0020034087	El. box grommet - divided	
27	0020034088	Clip - Pump	
28	0020034089	El. panel - back J	

Wall-hung boilers (fan-assisted system)

12KTO/17 PANTHER

00 - General view

Pos.	Article	Description	Note
29	0020034090	El. panel J	
30	0020034094	Gasket, fan J, (x5)	
31	0020034104	Hose arm. 3/8-3/8-elbow 30cm	
32	0020034106	Reflex foil -II	
33	0020034114	O-Ring, 14x9,5x2,5, (x10)	
34	0020034119	El. panel catch J	
35	0020034120	Clip - Pump	
36	0020034122	Pressure sensor clip	
37	0020034123	Pressure sensor reduction	
38	0020027600	Wire, supply pump	
39	0020034152	Wire	
40	0020034654	Seal. tape self-stick 5x218x15	
41	0020034655	Seal. tape self-stick 3x488x15	
42	0020086931	Sea. tape self-stick 18x20x893	
43	0020034676	BLOCK 24KXO15-inlet	
44	0020034697	Gasket with glass	
45	0020034703	Delimitation stick - short	
46	0020035606	Blind flange 1/2 - v.12	
47	0020027605	Air pressure switch	
48	0020034876	Burner 401.0929.02	
49	0020025314	Heating exchanger - heating 12KW	
50	0020027629	Expansion vessel, 5l	
51	0020034879	Base of comb. cham. 12	
52	0020043892	Strip of comb. chamb. left	
53	0020043893	Strip of comb. chamb. right	
54	0020034880	Gas tube 12	
55	0020034881	Inlet tube CHW 12	
56	0020034882	Outlet tube HHW 12	
57	0020034885	Front cover turbo 12	
58	0020034888	Shield D34 - 12 kW	

Wall-hung boilers (fan-assisted system)

12KTO/17 PANTHER

00 - General view

Pos.	Article	Description	Note
59	0020034890	Fan GR01285	
60	0020034893	Wire Q-253 electrodes	
61	0020035614	Washer of exch. holder	
62	0020034920	SELF ADH.SEAL TAPE 15X248X10	
63	0020044002	Flue system reduction SD	Unavailable!
64	0020034971	Air vent 1/4-ART.347	
65	0020035005	El. panel filling P16	
66	0020027676	Display board - J16	
67	-	-	not available
68	0020044678	El. panel foil Panther 17	
69	0020035043	Mount sensor 18mm-JS3227/17	
70	0020027653	Control board 24KXV17	
71	0020025271	Pressure relief valve 300kPa	
72	0020035622	Combustion conductor 12kW-17	
73	0020035620	Cover, front 12KOO,KTO17 - SP	
74	0020035624	Wire 12KTO17	
75	0020035626	Turbo base v.17	
76	0020035621	Frame, support 12KTO, KOO15 - SP	
77	0020035320	Beam, hydroblock 12KTO, KOO15 - SP	
78	-	-	not available
79	-	-	not available
80	0020035271	Cover, side R v.17 - SP	
81	0020035272	Cover, side L v.17 - SP	
82	0020035044	Air valve-pump	
83	0020027645	El. box for pump WILO	only for standard pump 0020023217, not for HE pump
84	0020027678	Coil for SIT SIGMA 840,843,845	